



ROLLING SHUTTERS



GANDHI
Automations Pvt Ltd

India's **No.1** Entrance Automation & Loading Bay Equipment Company

EUROPEAN COLLABORATION AND TECHNOLOGY WITH INNOVATIVE AND CREATIVE ENGINEERING FOR MORE THAN 30 YEARS



A PARTNER WHO STANDS BY YOUR SIDE

Quality & Safety - Our Priority

All automation for Rolling Shutters & Grills are CE certified, manufactured in accordance with

Standard(s) : EN 13241-1 : 2003+A1: 2011

Directive(s) : 2006/42/EC, 2004/108/EC

Optional : IS 6248

Gandhi Automations design, develop, manufacture and execute its products strictly in accordance with the above mentioned EN standards.

You are assured with our best quality products, safe operation and after sales service 24/7.



**10
YEARS**

**GUARANTEED
AVAILABILITY**

CRISIL

An S&P Global Company

Ratings



**TÜV
AUSTRIA**
CERTIFIED

EN ISO 9001
20100233018576
EN ISO 14001
20104233018577
ISO 45001
20116233018578



ORIGINAL SPARE PARTS

Guaranteed original spare parts availability for 10 years

CONTENTS

4	Our Quality for Your Safety
6	Gandhi Rolling Shutters - Quality Engineered
8	Curtain Profiles
12	Range of Gandhi Rolling Shutters
14	Special Requirements
18	Drive Units for Industrial, Commercial & Residential Rolling Shutters
22	Safety Brakes
24	Control Units for Three Phase Motors
25	Compact Gear Operators
26	Accessories - Operating & Controlling Options
28	Technical Specifications
32	Fire Rated Rolling Shutters - Fire Warrior



Our Quality For Your Safety

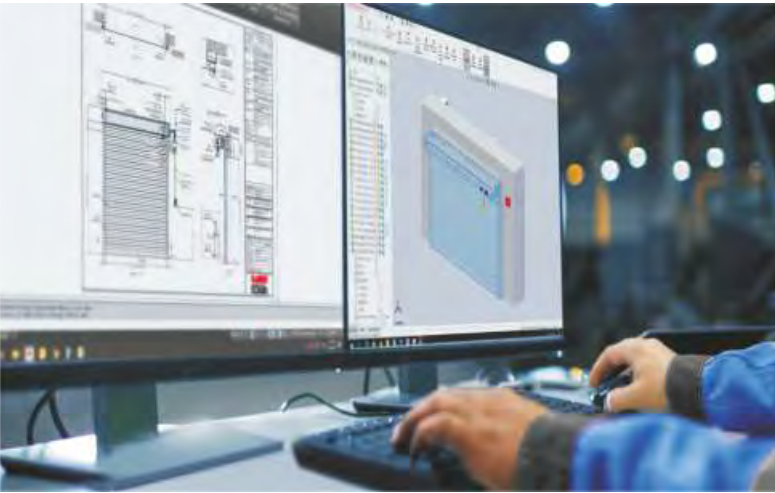

Gandhi Automations Pvt Ltd is India's No.1 Entrance Automation & Loading Bay Equipment Company. Since 1996, we have been designing, manufacturing, exporting and installing products that are hassle-free, safe and easy to operate. Gandhi Automations Pvt Ltd is a globally well-renowned brand, which is a result of years of hard work, innovation, commitment to quality & reliable customer service. We are a Government of India recognised 'Star Export House'.

Our comprehensive product portfolio consists of :

High Speed Industrial Doors, Dock Levelers & Dock Shelters, Rolling Shutters, Sectional Overhead Doors, Aircraft Hangar Doors & Shipyard Doors, Gates & Boom Barriers.

Head Office

Headquartered in Mumbai, the commercial capital of India, our company has expanded its manufacturing capacity, operations, geographical reach and customer base globally. Today our products are marketed by us and our distributors in more than 70 countries across the globe.

Competent Advice

Proper customer guidance and service are our top priorities. Our well trained and experienced specialists are always at your disposal from the project planning stage to final stages of handover, inspection as well as training. They help you choose a perfect product solution tailored to meet your requirements.



Quality Management

The company caters to following certifications : ISO 9001:2015, ISO 14001:2015 and ISO 45001:2018 by TÜV Austria. This has resulted in implementing continuous improvement towards personnel training, production, equipment calibration, machinery maintenance, logistics and customer relations.

Nationwide Network

Ahmedabad	■	Goa	■	Kolkata	■	Raipur	■
Bengaluru	■	Guwahati	■	Lucknow	■	Ranchi	■
Bhopal	■	Hyderabad	■	Mangalore	■	Surat	■
Bhubaneswar	■	Indore	■	Nagpur	■	Vadodara	■
Chandigarh	■	Jaipur	■	New Delhi	■	Visakhapatnam	■
Chennai	■	Jamshedpur	■	Patna	■		
Coimbatore	■	Kochi	■	Pune	■		



Advance Manufacturing

Our strategically located state of the art manufacturing and warehousing facility of 8,00,000 sq. ft. near Bhiwandi (40km NE of Mumbai) ensures high-quality product output and short delivery time.

The constant innovation and creative engineering applications of Gandhi Automations is a result of extensive and accurate in-house research and development.

All essential product components & accessories as well as control technology units are designed in-house and produced using European collaboration and technology.

Our product engineering team uses latest software applications combined with advanced machinery to offer our customers an excellently engineered, efficient and finished product.

Installation, Commissioning & Service

Our team of committed and diligent engineers and technicians are at your service round the clock; many of whom are trained at advanced training centers in Europe so as to ensure perfect installation and trouble-free commissioning according to the specifications. Thus, always assuring product reliability and longevity.



Packaging & Dispatch Area

Special care and all necessary precautions are taken while packaging the products for dispatch. Each consignment is supervised by a team of experts who ensure that material is dispatched safely, efficiently and promptly.



Dynamic Customer Service

Our Customer Care team offers 24x7 service. We lay great emphasis on exceptional after-sales service and provide spares, preventive maintenance and AMC (annual maintenance contracts) for minimum downtime ensuring durability and drive maximum ROI.

Our widespread service network assures response time to be minimum.

In rare case of any product failure, all you need to do is reach for the telephone.



TOLL FREE

1800 209 0200

From Anywhere in India

One call and our highly trained service technicians will be on their way in a fully equipped customer service van with wide range of original spares.

Rolling Shutters - Quality Engineered





Gandhi Rolling Shutters are ideal for situations where side room is at a premium and security is required. Our Rolling Shutters require very little headroom above the structural opening. They combine strength with elegance along with durability and are designed for both external and internal applications.

Gandhi Rolling Shutters are fabricated of interlocked Galvalume, Galvanised Insulated and Non Insulated, Stainless Steel, Patented Aluminium and Bright Steel Bar Rolling Grills.

Each of our Rolling Shutters is solidly constructed to promote trouble-free operation and long life. The Rolling Shutters can also be designed as per client's specifications or conforming to IS 6248.



Curtain Profiles



Curtain Profiles



Curtain is fabricated of interlocking profiles of

- Single Skin Galvalume Steel / Galvanised Steel
- Single Skin Stainless Steel 304 / 316

- Single Skin Extruded Aluminium alloy
- Double Skin Extruded Aluminium alloy
- Double Skin PUF insulated Aluminium / Galvanised Steel



Perforated single skin profiles help in achieving visibility, light infiltration and ventilation. The perforations prevent the wind load force from acting fully on the Rolling Shutter while maintaining visibility.

Single Skin extruded alloy aluminium profile.

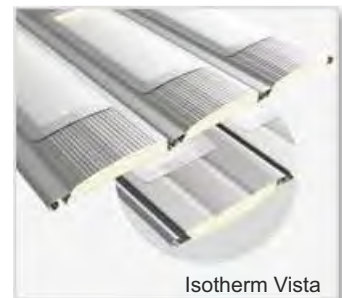
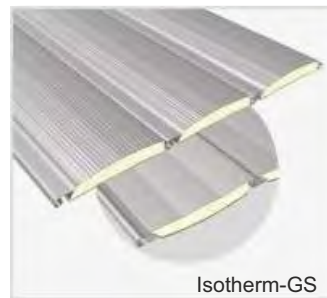
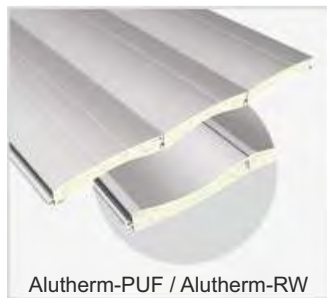
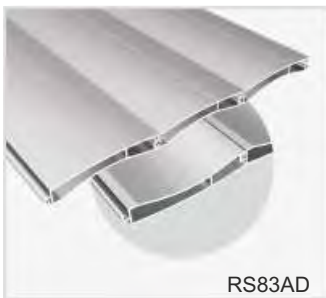

Double Skin aluminium extruded profile for heavy duty strength.

Rolling Shutters with Aluminium double skin PUF or Rockwool insulated / Galvanised double skin PUF insulated profiles combine energy efficiency with structural strength, durability, acoustic insulation, dust prevention and an overall aesthetic appeal.

The surface of these profiles is micro ribbed and profiles with Plexi Glass double glazing windows are also optionally available. The ends of alternate profiles are fitted with end locks to prevent lateral movement of profiles.

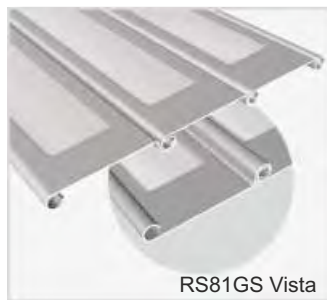

Rolling Shutters with single skin profiles are integrated with glazing windows optionally to provide visibility at eye level. Can be customised with vision window up to full width and height of Rolling Shutter.



Crystal

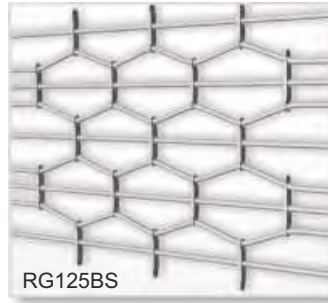

RG125BS

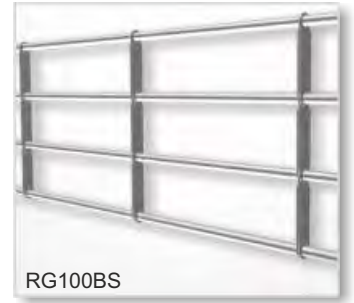

RG100BS

Crystal profile material is injection-molded polycarbonate, commonly known as bullet-proof glass. Rolling Shutters using Polycarbonate appears transparent hence serves as a perfect guard against theft, wind, dust. It is long lasting and prevents ultraviolet rays.

Wherever uncompromising protection and safe fresh air supply is asked for, then elegant Rolling Grill is the perfect solution. Available in Bright Steel Bar, they are the grills that will prove themselves in daily use again and again.

Choice of two unique designs catering to all requirements.



Guide Rails

The curtain is guided vertically by roll formed guides mounted on each side of the Rolling Shutter. The depth of guide rails depend on the width of the Rolling Shutters. Guide Rails are provided with PVC seals that ensure quiet shutter travel.

Special shaped 'Omega' guides with integrated rubber and brush seals ensure quiet shutter travel and also provide effective sealing. This is standard for Isotherm-GS / Alutherm-PUF / Alutherm-RW / Crystal Rolling Shutter where tight sealing is required.

TG guide made from Galvanised Steel are standard for other Rolling Shutter models. TG guides with integrated rubber ensure sealing and quiet shutter travel. Storm guides constructed from Mild Steel are applicable for larger shutter width.



Bend-resistant Aluminum bottom

The Aluminium bottom is fitted with EPDM rubber seal (DIN 7863). The seal prevents penetration of dirt and rain, weather sealing the lower edge of the Rolling Shutter and does not produce any noise when in contact with the floor. The seals also act as deterrent against pests and rodents.

Available on request is safety edge, when in contact with obstruction the Rolling Shutter will stop and reverse to open position.







Bend-resistant Galvanised Steel bottom

A stable Galvanised Steel / Stainless Steel profile strengthens the Rolling Shutter curtain.



Our products are available in standard series with an untreated surface but on request we can provide polyurethane paint over one coat of epoxy primer.

Standard RAL Colours :

-  Silver Similar to RAL 9006
-  Grey Similar to RAL 7015
-  Blue Similar to RAL 5010
-  Orange Similar to RAL 2000

Any other RAL colour available on request, at surcharge.

Types of Rolling Shutters



Gear - Operated Mechanical Rolling Shutters

Gear Type Rolling Shutters are operated mechanically by using a hand crank / winding handle. Counter balancing of the shutter curtain weight is done by using high tension coil type springs (made from special steel spring wire) within strong suspension shaft to reduce deflection. The gear operation is through machine cut worm gear. These Rolling Shutters are ideal for small to medium size.

Electrically - Operated Rolling Shutters

Electrical Type Rolling Shutters are operated by using a range of electrical actuators capable of operating shutters of all sizes. They are made up of self-braking worm gear with hollow shaft, integrated limit switches, integrated safety brakes with overload protection. Operationally, these shutters are relatively easy, hassle free and extremely safe and operate by integrating the control accessories like push-button, key selector or remote controls. During downtime, the option for manual operation is also available.



Range of Gandhi Rolling Shutters



Galvalume Rolling Shutters

Galvalume Rolling Shutters are ideally suited for most types of Industrial and Commercial applications. The aluminium – zinc alloy coating offers excellent corrosion resistance. It retains the sacrificial properties of zinc relative to steel while aluminium provides a tough film of aluminium oxide to increase barrier protection. Galvalume Rolling Shutters continues to gain approval by specifiers, architects, building owners and many others due to its versatility, ease of use, aesthetics and long-term performance.



Galvalume Perforated Rolling Shutters

Galvalume Rolling Shutters with finely perforated profiles helps in achieving visibility, light infiltration and ventilation. Used extensively in shopping malls, garages and high street retail premises, perforated roller shutters present a most economical method of providing a secure closure to large or small openings. Rolling Shutters can either be fabricated entirely of perforated profiles or these special profiles can be selectively used to provide partial visibility.



Galvanised Insulated Rolling Shutters

Galvanised Insulated Rolling Shutters are designed for a variety of industrial, warehouse, loading bays and commercial uses. The PUF insulated Rolling Shutters combine aesthetically pleasing appearance with thermal / sound insulation and dust prevention. The shutters can be custom made to fit large openings and are ideal for situations where sideroom is at a premium and security is required.



Aluminium Insulated and Non-Insulated Rolling Shutters

Aluminium Insulated and Non-Insulated Rolling Shutters made of design patented extruded double wall aluminium profiles provide durability, efficiency and functionality while being light weight as well as robust. Aluminium Rolling Shutters being corrosion resistant can be installed in areas where it would be exposed daily to atmospheric conditions that cause corrosion.



Stainless Steel Rolling Shutters

Stainless Steel Rolling Shutters made of SS 304 or SS 316 interlocked profiles are high grade high performance Rolling Shutters easy to operate, install and have a very good corrosion resistance while providing an appealing finish. They are capable of withstanding adverse weather conditions, thus providing 100% safety and security.



Bright Steel Bar Rolling Grills

Honeycomb design of Rolling Grills provides attractive yet functional means to secure areas where public access must be restricted. Honeycomb Rolling Grills constructed of Bright Steel Bar are attractively patterned and are ideal for display windows of showrooms, shopping malls and perfectly match with any building's architecture and interior space. Rolling Grills provide optimal protection without sacrificing visual access, air circulation or light infiltration.

Special Requirements

Over Dimensional Rolling Shutter





We fabricate our products precisely to your application and building opening. This applies to the selection of correct material profile, colour and the size. In this way you receive your perfect, completely individual solution. We are happy to advise you on specific application requirement. Our Rolling Shutters fit openings to a maximum width of 40,000 mm and height of 40,000 mm with an endless array of options to satisfy both aesthetic consideration as well as working requirement.



Special Requirements

Vision Windows



Special Requirements

Wicket or Pedestrian Door



Wicket or pedestrian doors are access doors integrated within the Rolling Shutter that can provide access to pedestrians even while the Rolling Shutter is closed. With the installation of a wicket door the heat loss from the building can be reduced by the decrease in the number of times the shutter is operated making it energy efficient.

Wicket doors offer a very practical and convenient solution for pedestrians who need to use the entrance frequently.

Drive Units

For Industrial, Commercial & Residential Rolling Shutters



- Sideone is a drive unit for Rolling Shutters
- Designed for a direct drive installation to the Shutter shaft
- The chain transmission is an option (for heavy Rolling Shutters)

Sideone is made up of

- A worm gear with hollow shaft
- An electric motor
- Integrated limit switches
- An electric motor
- An emergency manual operation

The self-braking worm gear makes the Sideone irreversible. No need for an electric brake.

Additional Details

European Directives

Sideone is made in accordance with product standards EN 13241-1 Doors and EN 12453 Safety for power operated shutters.

Duty Rating

There is a relation between the weight of the shutter and the number of movements per hour so the motor duty rating varies according to the shutter weight.

Overload Safety Factor

Motor overload safety factor = 4 x the nominal motor amperage because the starting current of the Sideone can reach these levels for short periods.

Output Speed

The maximum admissible speed depends on the construction and type of shutter. The admissible closing speed shall be tuned so as to allow the operating forces to comply with EN 12453.

Manual Operation

The manual override devices (hand crank or handchain override) when power cuts-off, are based on a max strength of the end user of almost 40 kg. In big or extremely heavy shutters the manual override is only intended in down direction.

Holding Torque

The Sideone drive unit is capable of holding the weight of the shutter without slippage.

The holding capability is the admissible load bearing of the worm gear construction.

Sideone

Side motors with integrated safety brake for industrial and commercial shutters

Three-phase
GAPL25TC.18

Override options

Emergency manual operation types

- Hand Crank
- Hand Crank Override

Limit switch options

Limit switch types

- Mechanical Limits
- Digital Limits



Dimensions (mm)

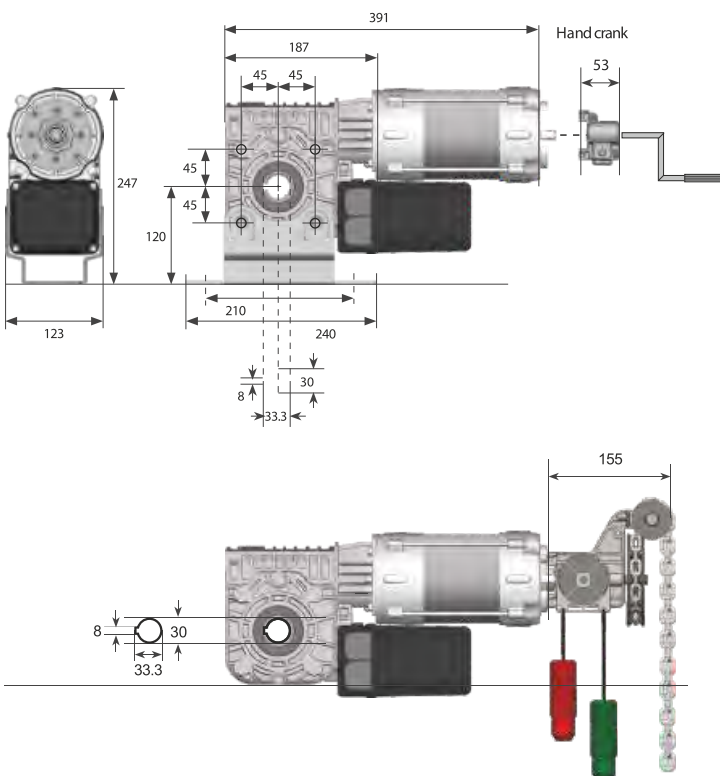

Technical details

Power supply (V~)	415
Frequency (Hz)	50
Torque (Nm)	250
Output speed (min ⁻¹)	12
Power (kW)	1.1
Absorption (A)	3.0
Max cycles per hour	20
Limit switch max turns	18
Temperature	-5°C/40°C
Noise (dB)	<70
Protection rate (IP)	54
Weight (kg)	18

Higher range available on request

Sideone

Three-phase
GAPL65MTC.48



Override options

Emergency manual operation types

- Hand Crank
- Hand Chain Override

Limit switch options

Limit switch types

- Mechanical Limits
- Digital Limits

Dimensions (mm)

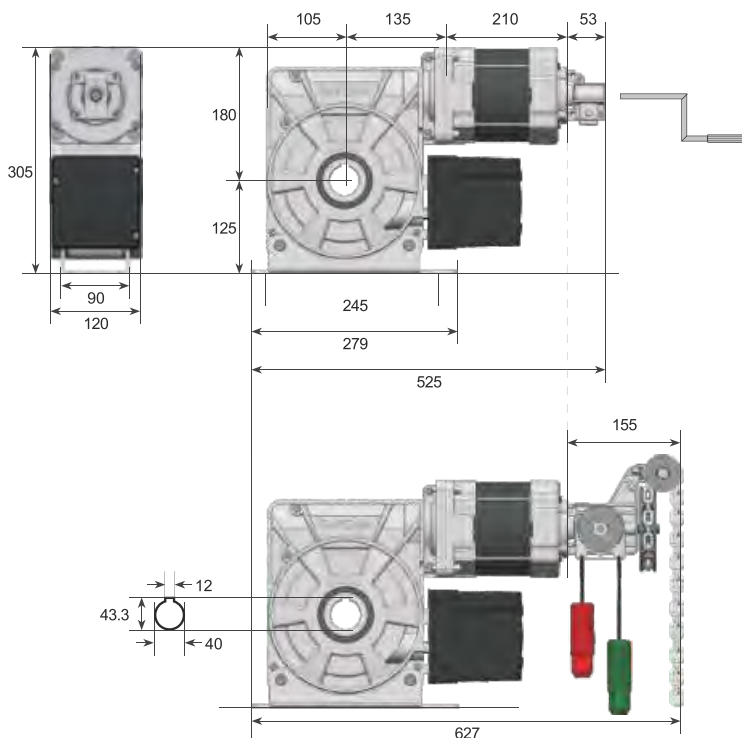

Technical details

Power supply (V~)	415
Frequency (Hz)	50
Torque (Nm)	650
Output speed (min ⁻¹)	12
Power (kW)	1.8
Absorption (A)	5.0
Duty rating (ED)	S3-50%
Limit switch max turns	48
Temperature	-5°C/40°C
Noise (dB)	<70
Protection rate (IP)	54
Weight (kg)	32

Higher range available on request

Torque Enhancement



Torque enhancement system is a special assembly for heavy industrial shutters. In installations with Sideone motors, the shutters shaft is driven by a chain transmission for heavy Rolling Shutters.

Due to the interchangeability of the output shaft the assembly can be installed on the left or right side of the shutter.

The set is made up of :

- The Sideone motor with mechanical limit switch
- A safety brake (RSB10A, RSB15A, RSB20A or RSB30A according to the type of assembly)
- A special bracket for the chain transmission, sprockets, chain and a set of screws

Safety Brakes



The safety brake is a safety device for Rolling Shutters without springs performing two functions

- A bearing support for the shutter's shaft
- A mechanical brake blocking the descent of the shutter if sudden acceleration occurs

It is made up of antioxiding materials, consists of a central body with a hollow shaft and is supported by a floating metal base preventing any tube eccentricity.

Gaposa safety brakes are equipped with a patented shock-absorber system and a microswitch for disconnecting the electrical supply to the motor when the brake locks.

In order to select the most suitable model for the best application, a good understanding of the safety brake data is essential.

Nominal torque

It is the key value to select the most appropriate safety brake according to the weight of the shutter and the diameter of the tube. Make sure that the torque of the operator is less than the nominal torque of the safety brake.

Locking torque

It is the maximum stress which the safety brake is subjected to when it stops the rotation of the shaft.

Working speed

It refers to the number of revolutions where the safety brake works as a simple support without functioning as a safety device. The speed of the shutter tube has to be within this value.

Range

RSB10A 1000 Nm

RSB15A 1551 Nm

RSB20A 2200 Nm

RSB30A 3109 Nm

RSB10A
RSB15A
RSB20A
RSB30A



	RSB10A	RSB15A	RSB20A	RSB30A
Nominal torque (Nm)	1000	1551	2200	3109
Locking torque (Nm)	3560	8842	16588	-
Working speed (min ⁻¹)	12	12	12	8
Screw tightening torque (Nm)	81	12	26	30
Approval number	TorFV 5/067	TorFV 7/126	TorFV10/155	-
Weight (kg)	12.5	19.5	20	45

RSB10A
RSB15A
RSB20A
RSB30A

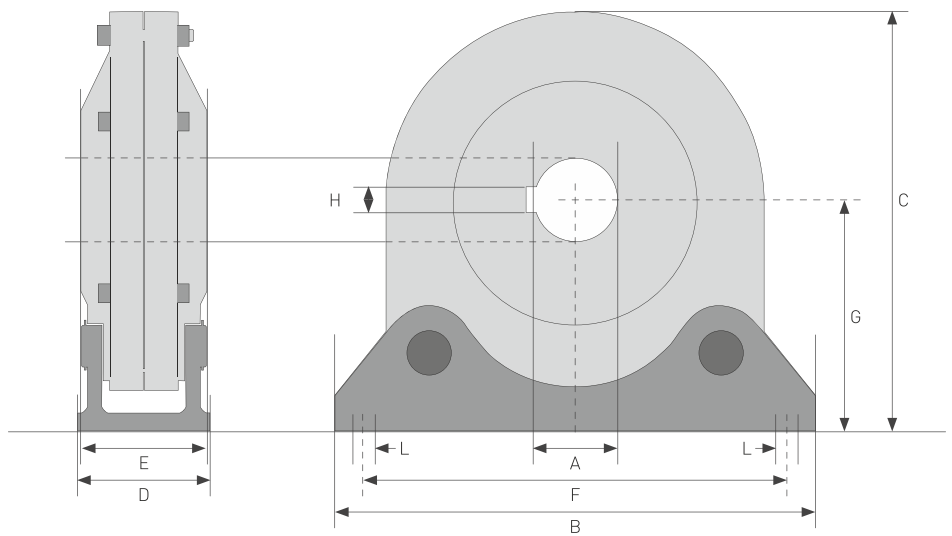

Segment (mm)	RSB10A	RSB15A	RSB20A	RSB30A
A	40	50	65	70
B	280	320	345	415
C	260	265	290	348
D	71	71	71	104
E	57	58	63	105
F	240	290	315	365
G	156	140	153	191
H	12	14	18	20
L (Ø)	16	17	17	22
Fastening screws	2 x M14	2 x M16	2 x M16	2 x M20

Control Units for Three Phase Motors

CB300

Control unit for three-phase motors



Features

- 3phase control unit
- More room while wiring
- Quick connections for power and limits cable
- Integrated buttons in the front cover for UP, STOP and DOWN control
- Inter-locked contactors for the best reliability
- Selectable safety input = optoelectric safety edge / nc contacts for safety beams
- Auto-check
- Selectable DOWN operating mode= dead man / momentary
- Automatic closing (selectable timing)
- Colors / sequences of led for visual display of the main functions/troubleshooting
- Parallel connection facility for grouping more CB300 in one push button
- IP rating: 54

Technical Specifications

Description	CB300	CB500
Power supply (V~)	415V~ (3Ph) - 50/60 Hz	415V~ (3Ph) - 50/60 Hz
Power supply External accessories	24V~ / max 70mA	24V~ / max 250mA
Motor power	max 4 kW	max 4 kW
Protection rate	IP54	IP54
Working temperature	-10°C / +60°C	-10°C / +60°C
Dimensions (mm)	133 x 208 x 80	210 x 305 x 120

CB500

Control unit for three-phase motors



Features

- 3phase control unit for the control of motors with digital or mechanical limit switches
- Integrated buttons in the front cover for UP, STOP and DOWN control
- Display and keyboard for the programming of limit switches and managing of the functions
- Different operating mode
- 3 entries for anti - crushing safety devices:
 - optoelectronic safety edge
 - photocells
 - safety edge
- Prepared for the addition of a radio receiver
- Prepared for the addition of a module for the management of a traffic light / courtesy lights
- Input for an external control panel
- More room while wiring

Compact Gear Operators

This is another operator with advance technology having patented safety mechanism in an unlikely event of chain failure. The operator with an IP40 protection rating works on a very low vibration and decibel level. Motor has a long performance life.

Features

- Attractive appearance, compact motor and strong lifting power
- High quality extruded aluminium alloy outer case
- Inbuilt limit switches and manual chain override in case of power failure
- Low vibration and noise
- Motor automatically protected from thermal overload by internal thermal probe
- Patented safety mechanism in case of chain failure
- Space and installation efficiency increases due to motor's compact size
- An external safety brake is a safety device available for blocking the fall of the shutter

Safety Brake



* Made in PRC

Technical Specifications

Model		CRS600	CRS1000	CRS1500	CRS2000
Rated output torque	Nm	412	809	1617	2450
Rated output speed	rpm	4.8	3.5	5.2	3.6
Motor power	W	370	400	1000	1000
Rated voltage	V/Hz	230/50	230/50	415/50	415/50
Rated current	A	3.3	4.9	3.8	4.1
Continuous working time	min	7	7	15	15
Max lifting	kgs	600	1000	1500	2000

Accessories



Operating & Controlling Options



Manually Operated Controls

Push-buttons are used predominantly for personnel traffic. Mounted on walls or columns in the vicinity of a shutter.



Radio Remote Control

Radiographic operation offers the possibility of selective operation. Only vehicles or personnel with a transmitter can open or shut the shutter.



Safety Device & Equipment

Visually signifies door operation



Push Button

Plastic housing IP 65



Three Station Push Button

"Open / Emergency - Stop / Close"

Plastic housing IP 65

1-Channel Polyvalent Transmitter



Simple and smooth design - perfect for every location.

Infra-Red Photocells

Functions

- Open: The shutter opens when the photocell beam is interrupted.
- Safety: The shutter remains open as long as the photocell beam is interrupted.



Key Selector



Surface mounted key switch European cylinder (DIN 18252) Aluminium casing

Bottom Safety Edge



Exclusive active bottom safety bar in conductive rubber to reverse motion when shutter is closing if an obstacle is hit.

Flashing Light



Visually signifies shutter operation. Flashing light serves safety requirements. They give visual signals for opening and closing impulse.

Plastic housing IP 65

Rotary Switch



Twisty rotary switch for surface mounted installation.

Receiver



Operating modes:

- Hold to Close / Open
- Hold to Close / Automatic Up

Technical Specifications

◦ = Optional - = Not Applicable

Door Type		RS78GI	RS78GI Venti
Profile Type		RS78GI	RS78GI Venti
Material		Galvanised Steel (Galvalume Steel available on request)	
Material Thickness (mm)		1.0 / 1.2	
Surfaces Without Colour Coating		Galvanised without protective paint	
Surfaces With Colour Coating		◦	
Profile Height (mm)		78	
Curtain Weight	kg/m ² Approx.	13.0 / 15.5	12.0 / 14.5
Wind load EN 12424	Class 2 upto door width in mm Higher wind loads on request	10000	◦
Acoustic Insulation	EN 717-1	-	
Thermal Insulation	Appendix B EN 12428	-	
Curtain Material	Single-skinned steel	Standard	
	Double-skinned steel	-	
	Double-skinned aluminium	-	
Curtain Surface	Galvanised Steel	Standard	
	Galvanised Steel natural finish	-	
	Galvanised Steel precoated in RAL 9006	-	
	Stainless Steel matt finish	-	
	Aluminium with one coat of grey epoxy primer by spray	-	
	Bright Steel with one coat of grey epoxy primer by spray	-	
Structural Shape		Curved	
Standard Dimensions (mm)	(Clear Width X Clear Height)	10000 x 10000	
Larger Dimensions On Request		Available	
Seals	On bottom	Standard	
Locking Arrangement (applicable only for GS Bottom Profiles)	Internal locking	◦	
	External / internal locking	◦	
Side Guides		2 to 2.5mm thick Galvanised Steel, seals available on request on side guides	
Finish		One coat of grey epoxy primer by spray	
Wind Locks, Storm Anchors		◦	-
Shaft		Steel tube with one coat of grey epoxy primer by spray	
Hood / Motor Cover		◦	
Bottom Profiles		<ul style="list-style-type: none"> • Bend-resistant Aluminium profile for additional strength • Weather resistant flexible EPDM tubular seal • Noiseless operation • Galvanised Steel profile available on request 	
Finish		One coat of grey epoxy primer by spray	

Classic Rolling Shutters

	RS81GI	RS81GI Venti	RS120GI	RS120GI Venti	RS78SS
	Galvanised Steel (Galvalume Steel available on request)		Galvanised Steel (Galvalume Steel available on request)		304 / 316 Stainless Steel
	1.0 / 1.2		1.0		1.0
	Galvanised without protective paint		Galvanised without protective paint		Stainless Steel with matt finish
	°		°		-
	81		119		78
	12.5 / 15.0	11.5 / 14.0	15.8	13.5	13.0 / 15.5
	10000		10000		10000
	°		°		°
	-		-		-
	-		-		-
	Standard		Standard		Standard
	-		-		-
	-		-		-
	Standard		Standard		-
	-		-		-
	-		-		-
	-		-		Standard
	-		-		-
	-		-		-
	Flat		Curved		Curved, Flat (optional)
	10000 x 10000		10000 x 10000		10000 x 10000
	Available		Available		Available
	Standard		Standard		Standard
	°		°		°
	°		°		°
	2 to 2.5mm thick Galvanised Steel, seals available on request on side guides One coat of grey epoxy primer by spray		2 to 2.5mm thick Galvanised Steel with integrated seals ensure quiet shutter travel One coat of grey epoxy primer by spray		2 to 2.5mm thick SS304 / SS316 Steel, seals available on request on side guides Matt finish
	° -		° -		°
	Steel tube with one coat of grey epoxy primer by spray		Steel tube with one coat of grey epoxy primer by spray		Steel tube with one coat of grey epoxy primer by spray
	°		°		°
	<ul style="list-style-type: none"> • Bend-resistant Aluminium profile for additional strength • Weather resistant flexible EPDM tubular seal • Noiseless operation • Galvanised Steel profile available on request One coat of grey epoxy primer by spray		<ul style="list-style-type: none"> • Bend-resistant Aluminium profile for additional strength • Weather resistant flexible EPDM tubular seal • Noiseless operation One coat of grey epoxy primer by spray		<ul style="list-style-type: none"> • Bend-resistant Steel profile SS304/SS316 for additional strength • Weather resistant flexible EPDM tubular seal available on request • Noiseless operation Matt finish

Technical Specifications

◦ = Optional - = Not Applicable

Door Type		RS83AD	Alutherm-PUF	Alutherm-RW
Profile Type		RS83AD	Alutherm-PUF	Alutherm-RW
Material		Aluminium		
Material Thickness (mm)		2 x 1.1		
Surfaces Without Colour Coating		Aluminium with one coat of grey epoxy primer by spray		
Surfaces With Colour Coating		◦		
Profile Height (mm)		83		
Curtain Weight	kg/m ² Approx.	8	13	13
Wind load EN 12424	Class 2 upto door width in mm	8000		
	Higher wind loads on request	◦		
Acoustic Insulation	EN 717-1	-	Standard	
Thermal Insulation	Appendix B EN 12428	-	Polyurethane foam	Rockwool
Curtain Material	Single-skinned steel	-		
	Double-skinned steel	-		
	Single-skinned aluminium	-		
	Double-skinned aluminium	Standard		
Curtain Surface	Galvalume Steel	-		
	Galvanised Steel natural finish	-		
	Galvanised Steel precoated in RAL 9006	-		
	Stainless Steel matt finish	-		
	Aluminium with one coat of grey epoxy primer by spray	Standard		
	Bright Steel with one coat of grey epoxy primer by spray	-		
	Polycarbonate moulded lens	-		
Structural Shape		Curved		
Standard Dimensions (mm)	(Clear Width X Clear Height)	8000 x 10000		
Larger Dimensions On Request		Available		
Seals	On bottom	Standard		
Locking Arrangement (applicable only for GS Bottom Profiles)	Internal locking	-		
	External / internal locking	-		
Side Guides		2 to 2.5mm thick Galvanised Steel with integrated seals ensure quiet shutter travel. (Aluminium available on request)		
Finish		One coat of grey epoxy primer by spray		
Wind Locks, Storm Anchors		◦		
Shaft		Steel tube with one coat of grey epoxy primer by spray		
Hood / Motor Cover		◦		
Bottom Profiles		<ul style="list-style-type: none"> • Bend-resistant Aluminium profile for additional strength • Weather resistant flexible EPDM tubular seal • Noiseless operation 		
Finish		One coat of grey epoxy primer by spray		

Classic Rolling Shutters

RS107A	Isotherm-GS	Crystal	RG125BS	RG100BS
Aluminium	Galvanised Steel	Polycarbonate moulded lenses	Bright Steel	
2.0	2 x 0.5	3.0	8.0	10.0
Aluminium with one coat of grey epoxy primer by spray	Precoated Galvanised in standard colours	Polycarbonate	Bright Steel with one coat of grey epoxy primer by spray	
°	-	-	°	
107	104	107	127	100
13	13	9	12.5	20
10000	10000	9000	10000	
°	°	°	°	
-	Standard	-	-	
-	Polyurethane foam	-	-	
-	-	-	Standard	
-	Standard	-	-	
Standard	-	-	-	
-	-	-	-	
-	-	-	-	
-	Standard	-	-	
-	Standard	-	-	
-	-	-	-	
Standard	-	-	-	
-	-	-	Standard	
-	-	Standard	-	
Flat	Profile exterior & interior curved	Flat	Honeycomb	Rectangle
8000 x 10000	10000 x 10000	9000 x 9000	10000 x 6000	10000 x 6000
Available	Available	Available	Available	
Standard	Standard	Standard	Standard	
-	-	-	°	
-	-	-	°	
2 to 2.5mm thick Galvanised Steel with integrated seals ensure quiet shutter travel. (Aluminium available on request)	2 to 2.5mm thick Galvanised Steel with integrated seals ensure quiet shutter travel.	2 to 2.5mm thick, Galvanised Steel with integrated brush seals ensure quiet shutter travel	2 to 2.5mm thick Galvanised Steel, seals available on request on side guides	
One coat of grey epoxy primer by spray	One coat of grey epoxy primer by spray	One coat of grey epoxy primer by spray	One coat of grey epoxy primer by spray	
°	°	°	-	
Steel tube with one coat of grey epoxy primer by spray	Steel tube with one coat of grey epoxy primer by spray	Steel tube with one coat of grey epoxy primer by spray	Steel tube with one coat of grey epoxy primer by spray	
°	°	°	°	
<ul style="list-style-type: none"> Bend-resistant Aluminium profile for additional strength Weather resistant flexible EPDM tubular seal Noiseless operation 	<ul style="list-style-type: none"> Bend-resistant Aluminium profile for additional strength Weather resistant flexible EPDM tubular seal Noiseless operation 	<ul style="list-style-type: none"> Bend-resistant Aluminium profile for additional strength Weather resistant flexible EPDM tubular seal Noiseless operation 	<ul style="list-style-type: none"> Bend-resistant Aluminium profile for additional strength Weather resistant flexible EPDM tubular seal Noiseless operation Galvanised Steel profile available on request 	
One coat of grey epoxy primer by spray	One coat of grey epoxy primer by spray	Anodised in natural finish	One coat of grey epoxy primer by spray	

Fire Rated Rolling Shutters

British Standards and American (UL / FM) Standards



Fire Warrior



Fire Rated Rolling Shutters are rated physical fire barriers that protect wall openings from the spread of fire and are designed to close automatically in the event of fire or an alarmed event. Automatic closure will be thermally controlled by means of fusible link.

Motorised Fire Rated Rolling Shutter is tested & approved by Exova Warrington UK which comply with BS 476: Part 22: 1987 standards for stability and integrity for upto 4 hours.

Application includes industrial, commercial, institutional and retail projects where fire protection is required.

Curtain

Fire Warrior curtain is constructed from 79 mm cold rolled Galvalume / Galvanised Steel / Stainless Steel laths with a minimum thickness of 0.9 mm. The interlocked profiles are securely held using specially designed profile ends which act as a curtain alignment system thus eliminating lateral movement of the profiles.

Bottom Rail

Formed from Mild Steel flat bar and angle depending on door width, welded back through a centrally located galvanised steel flat plate.

Side Guides

Mild Steel angles of suitable size and thickness are bolted with support angles to support the guides to form a secure fix in the RCC / Steel structure.

Barrel Assembly

The roller barrel is manufactured from Mild Steel tube of suitable outside diameter and wall thickness to suit the shutter application and is un-sprung.

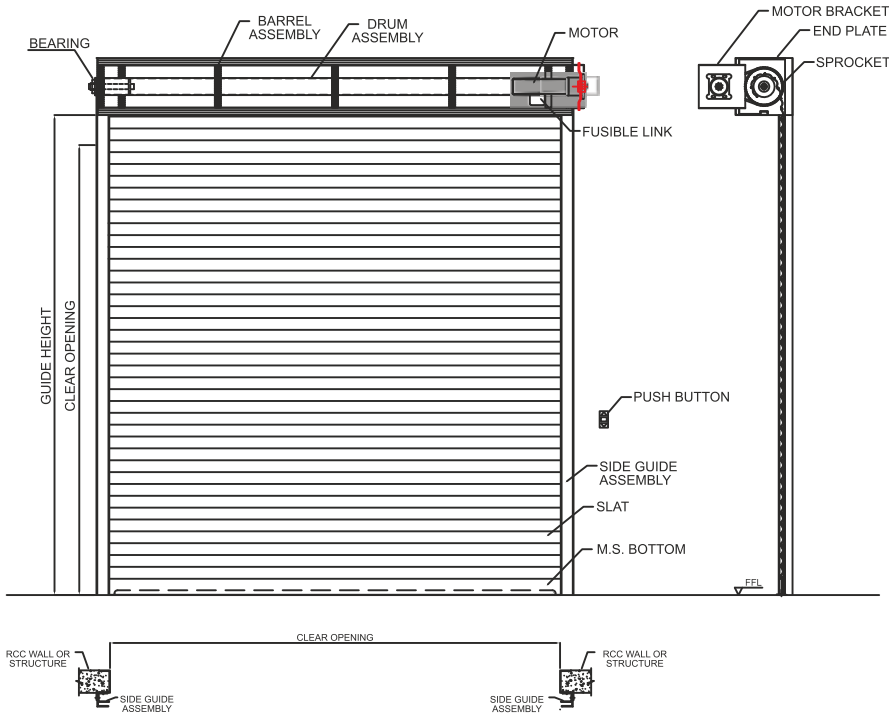

Hood

0.9mm thick pressed Galvalume / Galvanised Steel hood box complete with reinforced bracket as required to suit the shutter width.

Shutter Operation

Electrically operated: Shutters are fitted with a geared motor complete with a push button station with “UP”, “DOWN” and “STOP” buttons.

Auto - Closing Mechanism

All Fire Shutters are equipped with fusible link mechanism. Upon sensing a temperature of 74°C, the fusible link mechanism releases the brake of the motor and allows it to descend by gravity. Where Fire Shutters are needed to be activated by fire alarm signal, a dual fusible link (electric solenoid releaser) is used which releases the brake of the motor, upon receipt of a 24VDC, 400mA fire alarm signal. A reset pull is provided to reapply the brake on the motor.

Barrel Bracket Plate

Suitable design of thickness 4mm. Fitted with suitable anchor fasteners for fixing to the RCC / steel structure.

Technical Details of Operator

		GAPL- FRS1P-600	GAPL- FRS1P-1000	GAPL- FRS3P-1500	GAPL- FRS3P-2000
Rated output torque	Nm	412	809	1617	2450
Rated output speed	r/min	4.8	3.5	5.2	3.6
Motor power	W	370	400	1000	1000
Rated voltage	V/Hz	230/50	230/50	415/50	415/50
Rated current	A	3.3	4.9	3.8	4.1
Continuous working time	Min	8	8	13	13
Maximum lifting	kg	600	1000	1500	2000

Accessories

- Auto reset solenoid with fusible link
- Polyurethane painted in RAL Colours
- Audio visual fire control panels which can be connected to photo beams, smoke and heat detectors. Allowing full control over how the shutter will descent in fire condition

Additionally

At Gandhi Automations Pvt Ltd, we are also equipped to offer Fire Rated Rolling Shutters tested and certified to American Standards for upto 4 hours UL / FM Label.



Fire Shutter Test



Before the test



60 minutes of test



120 minutes of test



180 minutes of test



240 minutes of test



270 minutes of test - end of test





STAR EXPORT HOUSE
(Government of India Recognised)



Gandhi Automations operates a policy of continuous development and reserves the right to make technical modifications / replacements without prior notice.

GANDHI

Automations Pvt Ltd

India's No.1 Entrance Automation & Loading Bay Equipment Company

CORPORATE OFFICE

Chawda Commercial Centre, Link Road, Malad (W), Mumbai-400064, India

Tel : +91 22 6672 0200 / 6672 0300 (200 Lines)

Fax : +91 22 6672 0201

Email : sales@geapl.com

Website: www.geapl.com



TOLL FREE

1800 209 0200

From Anywhere in India

Ahmedabad - 93273 01555
 Bengaluru - 93435 09090
 Bhopal - 93292 94939
 Bhubaneswar - 93385 69889
 Chandigarh - 93176 41324
 Chennai - 93809 31777
 Coimbatore - 93452 99944
 Goa - 93731 37970
 Guwahati - 93248 98159

Hyderabad - 93473 75737
 Indore - 93034 64410
 Jaipur - 93520 41024
 Jamshedpur - 93219 76556
 Kochi - 93882 04774
 Kolkata - 93300 60855
 Lucknow - 93055 67760
 Mangalore - 93797 41352
 Nagpur - 93250 45410

New Delhi - 93131 99044
 Patna - 93219 76557
 Pune - 93245 30710
 Raipur - 93524 40068
 Ranchi - 93044 95570
 Surat - 93270 97410
 Vadodara - 93756 41357
 Visakhapatnam - 93463 34102