



FIRE RATED ROLLING SHUTTERS & FIRE SLIDING DOORS



GANDHI
Automations Pvt Ltd

India's **No.1** Entrance Automation & Loading Bay Equipment Company

EUROPEAN COLLABORATION AND TECHNOLOGY WITH INNOVATIVE AND CREATIVE ENGINEERING FOR MORE THAN 25 YEARS



Quality & Safety - Our Priority

Fire Rolling Shutters are tested and approved by Exova Warrington UK in accordance with BS 476: Part 22: 1987 certified or UL / FM Certified.

Fire Sliding Doors are CE certified according to EN 16034:2014 standard.



Gandhi Automations design, develop, manufacture and execute its products strictly in accordance with the above mentioned EN standards.

You are assured with our best quality products, safe operation and after sales service 24/7.

A PARTNER WHO STANDS BY YOUR SIDE

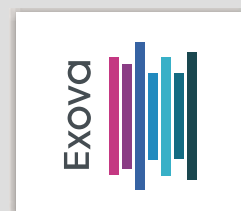
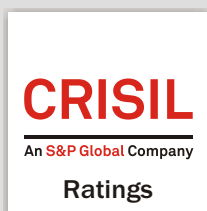

ORIGINAL SPARE PARTS

Guaranteed original spare parts availability for 10 years

CONTENTS

- 4 | Our Quality For Your Safety
- 6 | Fire Rated Rolling Shutters -
Fire Warrior, BS certified
- 9 | Fire Shutter Test
- 10 | Rolling Fire Doors - UL / FM certified
- 12 | Insulated Rolling Fire Doors -
UL / FM certified
- 14 | Accessories
- 16 | Fire Rated Sliding Doors -
CE certified as per EN 16034:2014 Standards
- 20 | Accessories

Efficiency, Safety and Flexibility

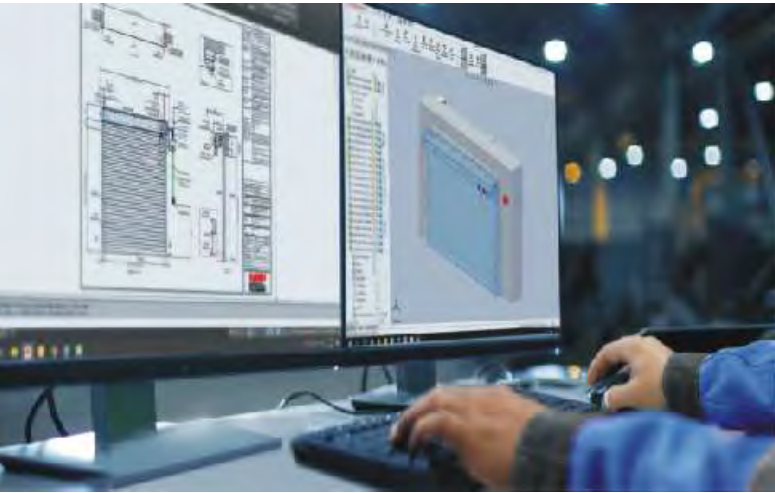

Gandhi Automations Pvt Ltd is India's No.1 Entrance Automation & Loading Bay Equipment Company. Since 1996, we have been designing, manufacturing, exporting and installing products that are hassle-free, safe and easy to operate. Gandhi Automations Pvt Ltd is a globally well-renowned brand, which is a result of years of hard work, innovation, commitment to quality & reliable customer service. We are a Government of India recognised 'Star Export House'.

Our comprehensive product portfolio consists of :

High Speed Industrial Doors, Dock Levelers & Dock Shelters, Rolling Shutters, Sectional Overhead Doors, Aircraft Hangar Doors & Shipyard Doors, Gates & Boom Barriers.

Head Office

Headquartered in Mumbai, the commercial capital of India, our company has expanded its manufacturing capacity, operations, geographical reach and customer base globally. Today our products are marketed by us and our distributors in more than 70 countries across the globe.

Competent Advice

Proper customer guidance and service are our top priorities. Our well trained and experienced specialists are always at your disposal from the project planning stage to final stages of handover, inspection as well as training. They help you choose a perfect product solution tailored to meet your requirements.



Quality Management

The company caters to following certifications : ISO 9001 : 2015, ISO 14001 : 2015, ISO 45001 : 2018 by TÜV Nord. This has resulted in implementing continuous improvement towards personnel training, production, equipment calibration, machinery maintenance, logistics and customer relations.

Nationwide Network

Ahmedabad	■	Goa	■	Kolkata	■	Raipur	■
Bengaluru	■	Guwahati	■	Lucknow	■	Ranchi	■
Bhopal	■	Hyderabad	■	Mangalore	■	Surat	■
Bhubaneswar	■	Indore	■	Nagpur	■	Vadodara	■
Chandigarh	■	Jaipur	■	New Delhi	■	Visakhapatnam	■
Chennai	■	Jamshedpur	■	Patna	■		
Coimbatore	■	Kochi	■	Pune	■		



Advance Manufacturing

Our strategically located state of the art manufacturing and warehousing facility of 4,00,000 sq. ft. near Bhiwandi (40km NE of Mumbai) ensures high-quality product output and short delivery time.

The constant innovation and creative engineering applications of Gandhi Automations is a result of extensive and accurate in-house research and development.

All essential product components & accessories as well as control technology units are designed in-house and produced using European collaboration and technology.

Our product engineering team uses latest software applications combined with advanced machinery to offer our customers an excellently engineered, efficient and finished product.

Installation, Commissioning & Service

Our team of committed and diligent engineers and technicians are at your service round the clock; many of whom are trained at advanced training centers in Europe so as to ensure perfect installation and trouble-free commissioning according to the specifications. Thus, always assuring product reliability and longevity.



Packaging & Dispatch Area

Special care and all necessary precautions are taken while packaging the products for dispatch. Each consignment is supervised by a team of experts who ensure that material is dispatched safely, efficiently and promptly.



Dynamic Customer Service

Our Customer Care team offers 24x7 service. We lay great emphasis on exceptional aftersales service and provide Spares, Preventive Maintenance and Annual Maintenance Contracts for minimum downtime ensuring durability and drive maximum ROI.

Our widespread service network assures response time to a minimum.

In rare case of any product failure, all you need to do is reach for the telephone.



TOLL FREE

1800 209 0200

From Anywhere in India

One call and one of our highly trained service technicians will be on its way in a fully equipped customer service van with wide range of original spares.

Fire Rated Rolling Shutters - Fire Warrior

BS certified





Fire Rated Rolling Shutters are rated physical fire barriers that protect wall openings from the spread of fire and are designed to close automatically in the event of fire or an alarmed event. Automatic closure will be thermally controlled by means of fusible link.

Motorised Fire Rated Rolling Shutter is tested & approved by Exova Warrington UK which comply with BS 476: Part 22: 1987 standards for stability and integrity for up to 4 hours.

Application includes industrial, commercial, institutional and retail projects where fire protection is required.

Curtain

Fire Warrior curtain is constructed from 79 mm cold rolled Galvalume / Galvanised Steel / Stainless Steel laths with a minimum thickness of 0.9 mm. The interlocked profiles are securely held using specially designed profile ends which act as a curtain alignment system thus eliminating lateral movement of the profiles.

Side Guides

Mild Steel angles of suitable size and thickness are bolted with support angles to support the guides to form a secure fix in the RCC / Steel structure.

Bottom Rail

Formed from Mild Steel flat bar and angle depending on door width, welded back through a centrally located Galvanised Steel flat plate.

Barrel Assembly

The roller barrel is manufactured from Mild Steel tube of suitable outside diameter and wall thickness to suit the shutter application and is un-sprung.

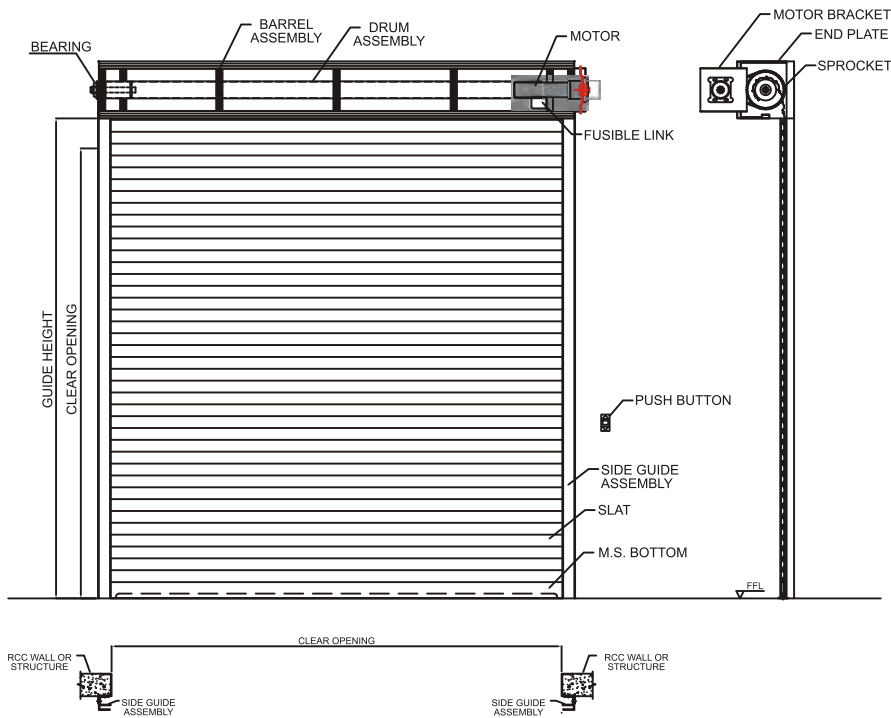

Barrel Bracket Plate

Suitable design of thickness 4mm. Fitted with suitable anchor fasteners for fixing to the RCC / steel structure.

Hood

0.9mm thick pressed Galvalume / Galvanised Steel hood box complete with reinforced bracket as required to suit the shutter width.

Shutter Operation

Electrically operated: Shutters are fitted with a geared motor complete with a push button station with “UP”, “DOWN” and “STOP” buttons.

Auto - Closing Mechanism

All Fire Shutters are equipped with fusible link mechanism. Upon sensing a temperature of 74°C, the fusible link mechanism releases the brake of the motor and allows it to descend by gravity. Where Fire Shutters are needed to be activated by fire alarm signal, a dual fusible link (electric solenoid releaser) is used which releases the brake of the motor, upon receipt of a 24VDC, 400mA fire alarm signal. A reset pull is provided to reapply the brake on the motor.

Accessories

- Auto reset solenoid with fusible link
- Polyurethane painted in RAL Colours
- Audio visual fire control panels which can be connected to photo beams, smoke and heat detectors. Allowing full control over how the shutter will descent in fire condition

Technical Details of Operator

Description		GAPL FRS1P-600	GAPL FRS1P-1000	GAPL FRS3P-1500	GAPL FRS3P-2000
Rated output torque	Nm	412	809	1617	2450
Rated output speed	r/min	4.8	3.5	5.2	3.6
Motor power	W	370	400	1000	1000
Rated votage	V/Hz	230/50	230/50	415/50	415/50
Rated current	A	3.3	4.9	3.8	4.1
Continuous working time	Min	8	8	13	13
Maximum lifting	kg	600	1000	1500	2000

Fire Shutter Test



Before the test



60 minutes of test



120 minutes of test



180 minutes of test



240 minutes of test



270 minutes of test - end of test

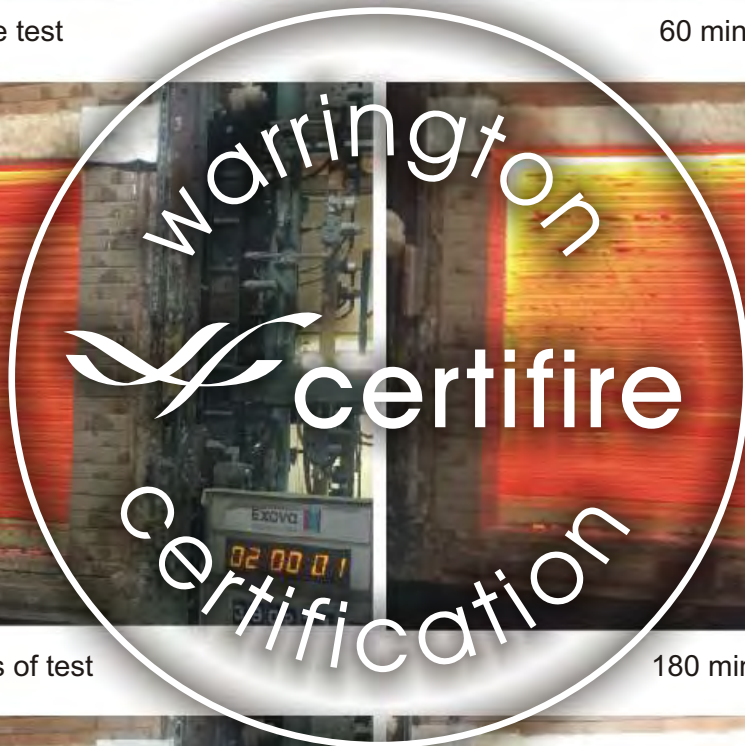

Rolling Fire Doors

UL / FM certified



Benefits

- UL Labeled - 4, 3, 1 ½, 1 and ¾ hour labels.
- FM Approval.
- Size Flexibility - each unit is built to exact opening size requirements up to 50' wide, 40' high or 1200 square feet.
- Durability - commercial duty design, little to no routine maintenance.
- Compact Storage - curtain stores in an overhead coil that is totally supported by the side guides.
- Drop Testing / Resetting - simplified systems available.
- Repairs - job records are retained and parts are readily available.

Available Options

- Battery Back Up Devices
- Project Specific wind load, seismic and LEED® calculations
- Annunciators
- Fuselink Switch Activation
- Vision windows
- Cylinder or slide bolt locking
- Smoke and heat detectors
- Bottom bar sensing edge for motorized units
- Operator covers for exterior mounted units or exposed operators below 8' H

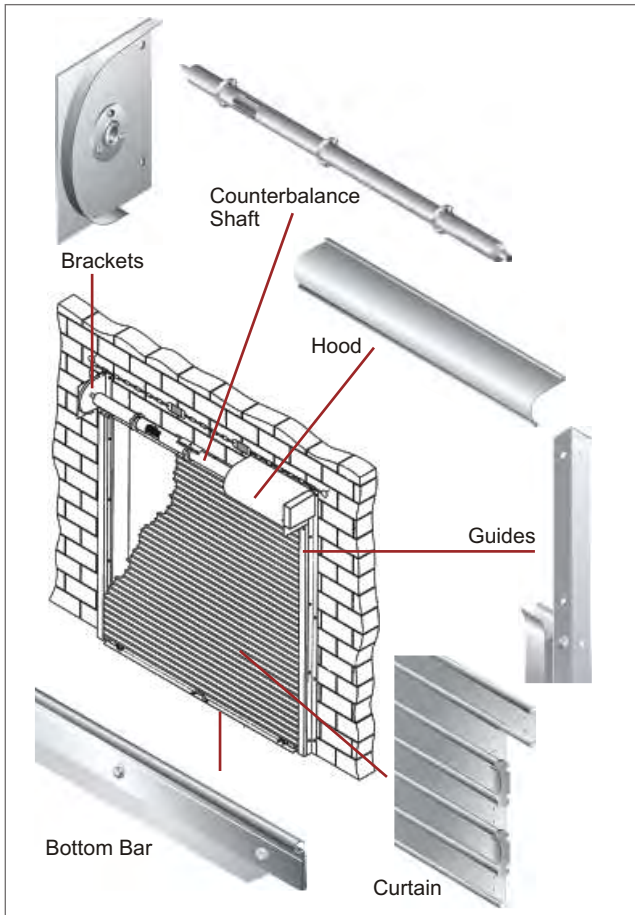

Brackets

Minimum 1/4" steel plates that bolt to the guide assembly and support the counter-balance shaft and curtain.

Standard Material & Finish : Steel with powder coating finish in grey, tan or white

Counterbalance Shaft

4 1/2" minimum diameter outer shaft and 1 1/4" minimum inner shaft. This assembly supports the curtain & contains counter-balance torsion springs for assisting operation.

Standard Material : Steel

Hood

Protective sheet metal curtain enclosure provides fire resistance at the head of the door and keeps the brackets rigid.

Standard Material & Finish : Galvanized Steel with exclusive finish in light grey, tan or white

Optional Material : Stainless Steel

Guides

Minimum 3/16" angle assemblies fasten to the wall and support the entire weight of the door.

Standard Material & Finish : Steel with powder coating finish in grey, tan or white

Optional Material : Stainless Steel

Curtain

Interlocking roll formed slats with metal endlocks riveted to ends of alternate slats to maintain slat alignment and prevent wear.

Standard Material & Finish : Galvanized Steel with exclusive finish in light grey, tan or white

Optional Material : Stainless Steel

Bottom Bar

Two 2" x 2" x 1/8" back to back structural Steel angles.

Lock mechanisms available.

Standard Material & Finish : Steel with powder coating finish in grey, tan or white

Optional Material : Stainless Steel

Operation

Push-up operation shown. Hand chain, hand crank and motors are available. Doors operate by rotating the shaft gear end. The opposite end of the shaft applies spring tension and is equipped with a spring adjusting wheel.

Mounting & Clearances

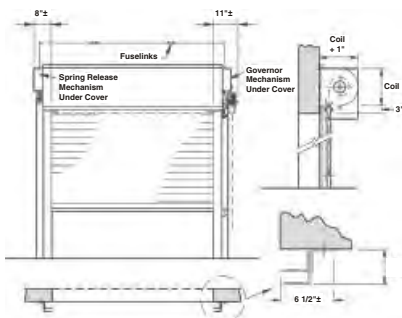

Face of Wall - Maintains clearance of full opening, minimal exposed components.

Fire doors are built to order to fit specific dimensions up to 50' wide, 40' high or 1200 square feet.

Consult factory for larger sizes.

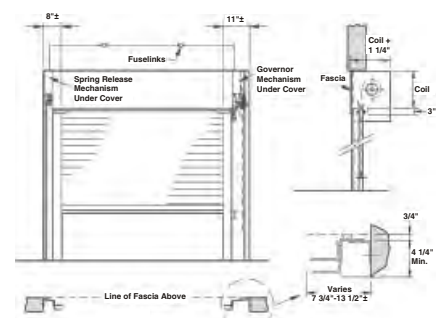

Between Jamb - Mounts within the opening, fascia (front hood closure piece) required.

Insulated Rolling Fire Doors

UL / FM certified



One Door - Many Benefits

Now you can provide UL rated fire protection plus security, sound attenuation, environmental separation and smoke control all with the insulated fire door. Reduce costs by specifying a single insulated door to meet multiple design needs, then continue to cash in on the energy savings generated by insulated door's sealing and insulation.

Achieve Rolling Steel Security with up to 4 hours of UL Labeled Fire Protection, plus:

- Sound Attenuation - A Sound Transmission Class rating based on testing a complete, operable curtain, makes insulated door's mineral wool insulated curtain an excellent choice to maintain fire wall integrity and reduce decibel levels. Use insulated door in schools, production facilities, hospitals, office buildings or anywhere that the combination of fire protection and sound attenuation is desired.
- Climate Control - Insulated door's curtain yields a 5.3 R-value that can be combined with full perimeter seals for use at exterior or interior openings whenever fire protection and environmental separation is required.

- Smoke Control - Insulated fire door is also available with a UL label for smoke and draft control. Specify insulated door with smoke shield construction and gain labeled protection against the passage of smoke and gases through the opening.

Other Available Features and Benefits

- UL Labels available for 4, 3, 1 1/2, 1 or 3/4 hour performance. Factory Mutual Approval
- Flame spread and smoke development index factors for insulated door's mineral wool insulation are zero as tested per ASTM E84.
- With each unit built to exact opening size requirements, you have size flexibility up to 30' wide and 22' high standard construction. Units up to 34' wide, consult factory.
- Specified Wind Load - doors can be configured to withstand the full range of specific wind load requirements. Third party performance validation. Seismic performance validation available per ASCE 7-05.
- Full range of finish, mounting and locking options.

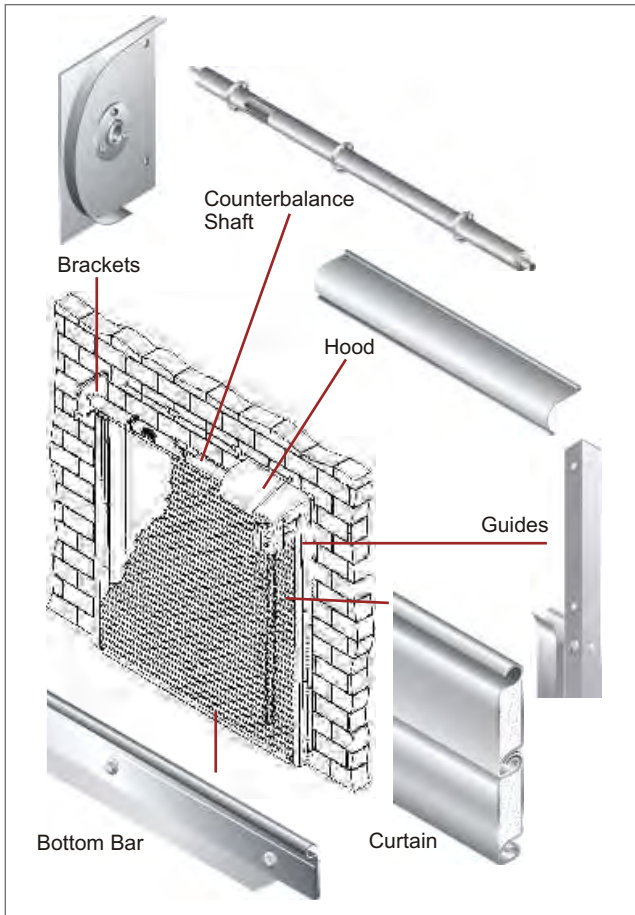

Brackets

Minimum 1/4" steel plates that bolt to the guide assemblies and support the counter-balance shaft and curtain.

Standard Material & Finish : Steel with powder coating finish in grey, tan or white

Counterbalance Shaft

4 1/2" minimum diameter outer shaft and 1 1/4" minimum inner shaft. This assembly supports the curtain & contains counter-balance torsion springs for assisting operation.

Standard Material : Steel

Hood

Protective sheet metal curtain enclosure that provides fire resistance at the head of the door.

Standard Material and Finish : Galvanized Steel with exclusive finish in light grey, tan or white

Optional Materials : Stainless Steel

Guides

Minimum 1/4" angle assemblies fasten to the wall and support the entire weight of the door.

Standard Material & Finish : Steel with powder coating finish in grey, tan or white

Curtain

Double skin interlocking roll formed slats filled with 7/8" thick mineral wool insulation. Combination cast iron endlock / windlocks are riveted to ends of alternate slats to maintain slat alignment, lock curtain into guides and prevent curtain wear. R-value is 5.3 as calculated using the ASHRAE Handbook of Fundamentals.

Exterior / Interior slat skins available in : 24/24 or 22/22 gauge Galvanized Steel, grey enamel or 22/22 Stainless Steel, #4 finish.

Standard Material & Finish : Galvanized Steel with exclusive finish in light grey, tan or white. White 24/24 only.

Optional Materials : Stainless Steel

Bottom Bar

Two 2" x 2" x min. 1/8" back to back structural Steel angles. Lock mechanisms available.

Standard Material & Finish : Steel with powder coating finish in grey, tan or white

Optional Materials : Stainless Steel

Operation

Chain operator standard. Crank operators are available. Fire Doors operate by rotating the shaft gear end. The opposite end of the shaft applies spring tension and is equipped with a spring adjusting wheel.

Mounting & Clearances

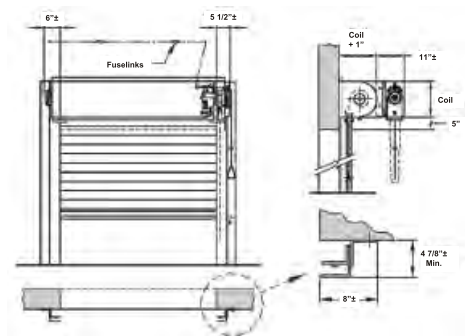

Face of Wall - Maintains clearance of full opening, minimal exposed components.

Standard construction Insulated Fire Doors are built to order to fit specific opening dimensions to 30' wide and 22' high. Large openings up to 34' wide, consult factory.

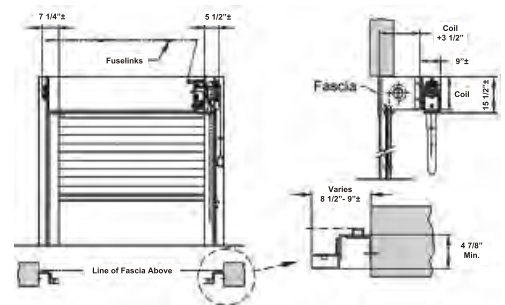

Between Jamb - Mounts within the opening, fascia (front hood closure piece) required.

Accessories



Battery Back Up Devices

Prevents the door from closing due to a power failure for a minimum of 4 hours. Fire door operators also functions as a DC power source for local warning devices and detectors to keep them functioning during a power outage.



Annunciators

Safety devices that provide a visual and/or audible advanced warning when the fire door is about to close. Can be activated upon alarm signal or loss of power when supported by a battery back-up device.



Vision Windows

Enhance life safety and convenience by allowing visibility to the other side of the firewall opening. Up to six 10" x 1 5/8" non-wired glass panes are available per fire door curtain for Rolling Fire Doors.



Optional Finishes

- Curtain and hood with finish in tan or white
- Stainless Steel, 300 series #4 finish for curtain, bottom bar and hood
- Hot-dip galvanizing on Steel components
- Powder coat finish in selected color
- Zinc Rich Grey corrosion resistant powder coating

Powder Coat Finish

Powder Coat Finish in a choice of over 200 colors adds durability and aesthetic value. Surface preparation and coating process produces a smooth, lasting finish.

Fire Rated Sliding Doors

CE certified as per EN 16034:2014 Standards





CROSSWALK EI 120 single leaf sliding door

CE certified as per EN 16034:2014 Standards

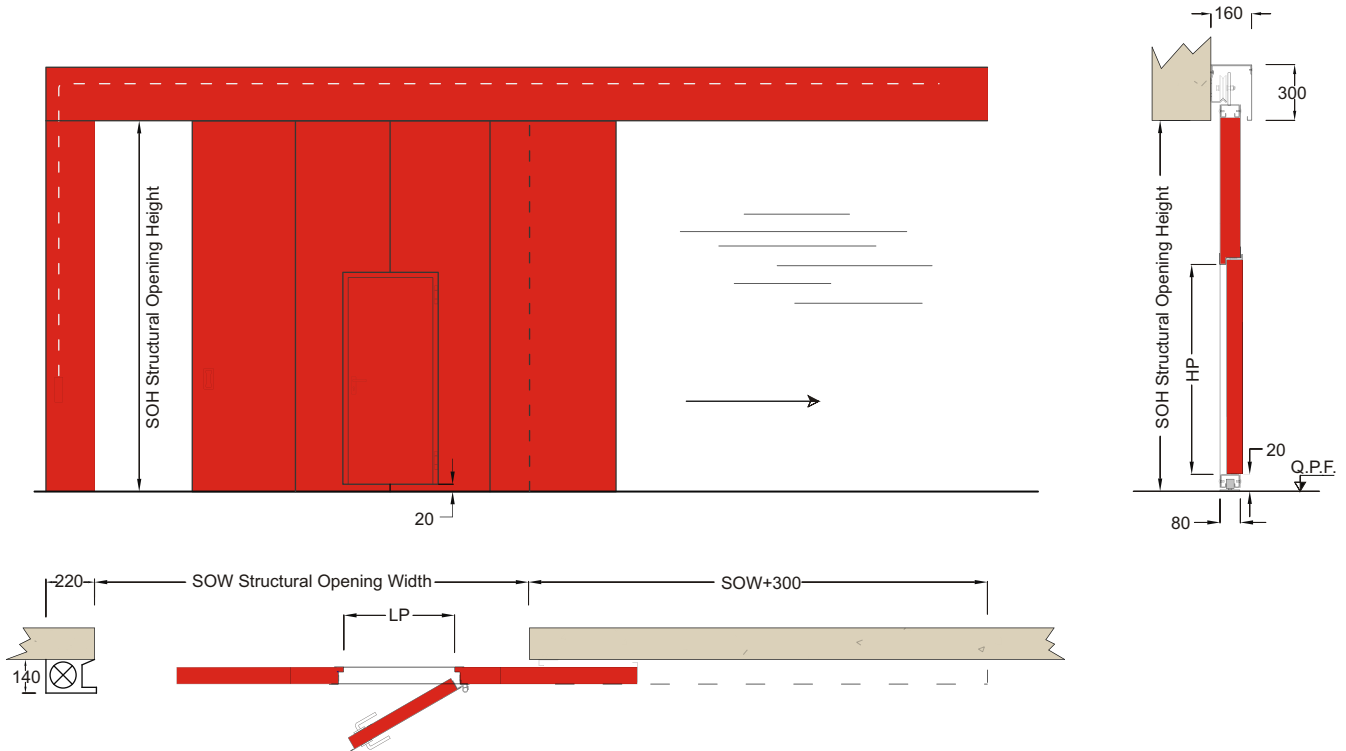

Sliding fire doors are ideal for large wall opening and, above all, for industrial doors.

OPERATING : Standard with fuse

The sliding door holds steady in every position it is left. The counterweight is linked to the fuse and closes the door only in case of fuse break.

With an area bigger than 12 sqm or on demand, an electromagnet could be supplied. The device is activated by a Fire Control System. The sliding door remains in a "normally open" position and goes to a complete closing in case of fire.

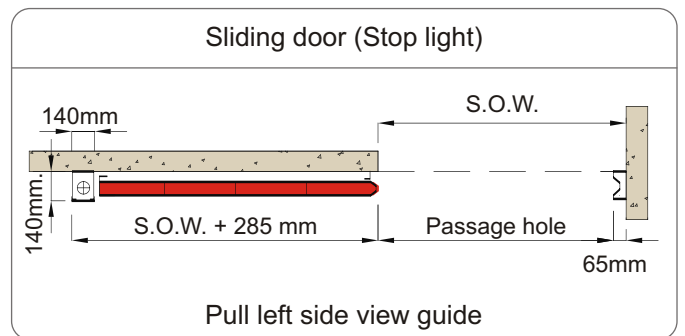
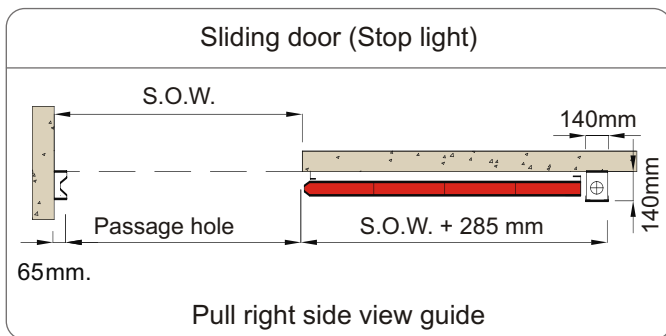
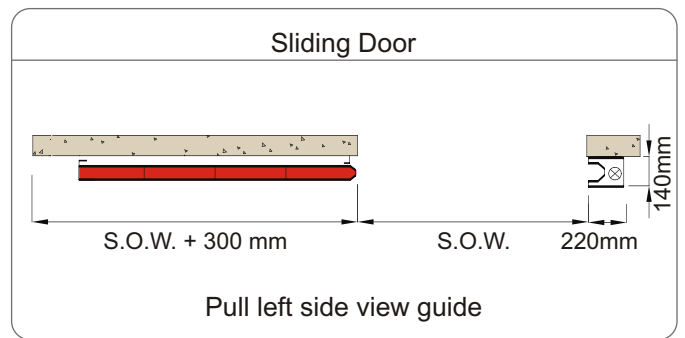
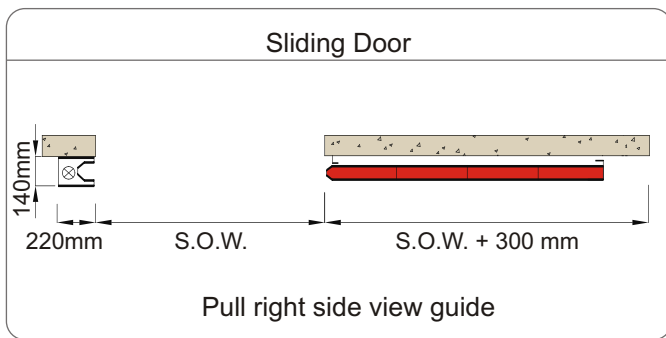

CROSSWALK EI 120 double leaves sliding door

CE certified as per EN 16034:2014 Standards

SEC. B - B'

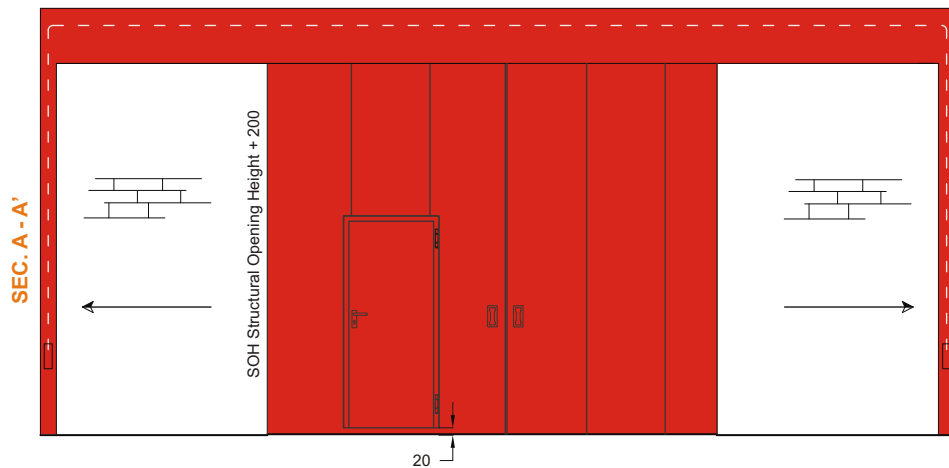

SEC. A - A'

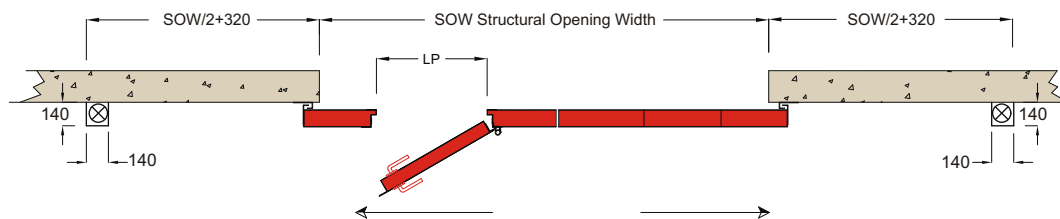

SPECIFICATIONS : EI 120

CROSSWALK sliding door EI 120 made of :

- Panels : by module to be assembled, 80 mm. total thickness, made of two pressbent steel plates electrically welded to the edge frame.
- Pedestrian Door : inside the leaf (option)
- Insulation : internal insulation made of rigid panels of high density material that creates a monolithic structure.
- Labyrinth seals : profiled steel section edge seals with self-expanding gaskets ready for mounting on the wall by screw (not supplied)
- Monorail : top 40/10 steel track designed for anchorage to the wall using expanding dowels. (not supplied) Bottom guide roller on the fitting side of end panel
- Hangers : sliding on double ball bearing
- Guide track : lower track shaped in the panel where the floor-anchored guide roller slides.
- Seal : self expanding seal on labyrinths, monorail, counterweight.
- Cover : guide track cover. The complete track and the lateral closing weight are covered with a sheet steel hood
- Counterweight : closure counterweight protected by press bent steel sheet ready to be installed by screws (not supplied)
- Handle : indented handle on both sides of the doors.
- Operation : standard with electromagnetic.
- Painting : with epoxy powders embossed standard colour RAL 7035 (light grey) without primer coating

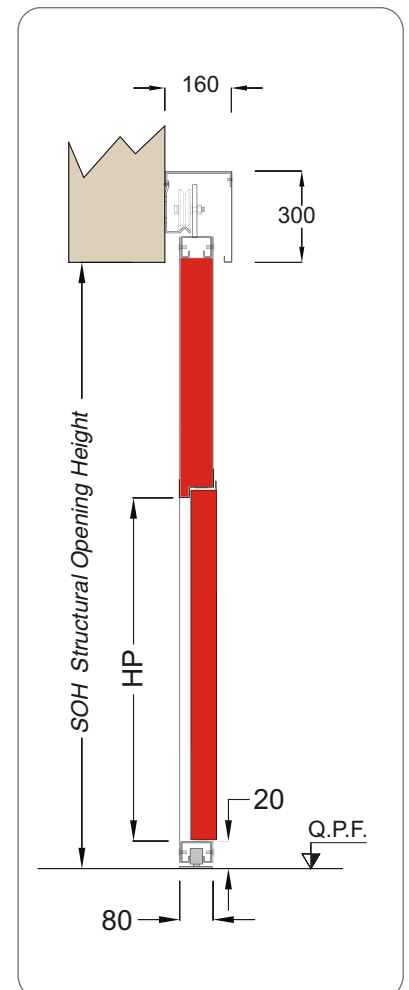

Note RADIAL DUMPER is obliged for sliding doors with dimension upper than 12 sqm for security reason.

Accessories

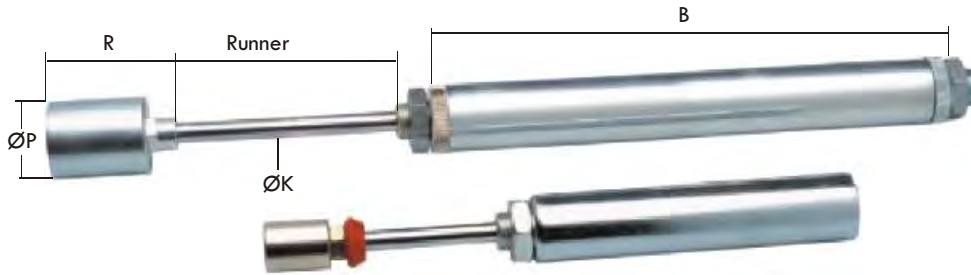

Shock Absorbers

Travel limit shock absorbers slow down sliding doors, absorbing their inertial force during closure. These can be adjusted using a limit valve through which the oil flows depending on the thrust and the number of openings. Shock absorbers have different characteristics depending on the mass of the door : C/60 Type and C/120 type.

They are installed on the sliding end panel which has an installation anchor bar welded to its frame.



Technical Details

Shock Absorber	C/60	C/120
Runner	60 mm	120 mm
Back re-opening	magnetic	magnetic
ØP	20	32
R	30	50
ØK	5	8,5
Width B	130	220

Holding Devices



Electromagnet with Trigger Release

Electromagnet consists of a fixed part that is mounted on the upper guide of the sliding door and a plate attached to the door. The separated trigger release is fixed in a comfortable position for the operator. They are connected to a smoke and temperature detection system and this guaranteed in case of opened normally position or switch off in case of fire.

Technical Details

Operating Voltage	24 VDC
Power	70 mA
Holding Force	600N (60 kg)
Insertion	100%
Mark	CE
UNI EN 1155	Fire door Regulations

Continuous Door Selector

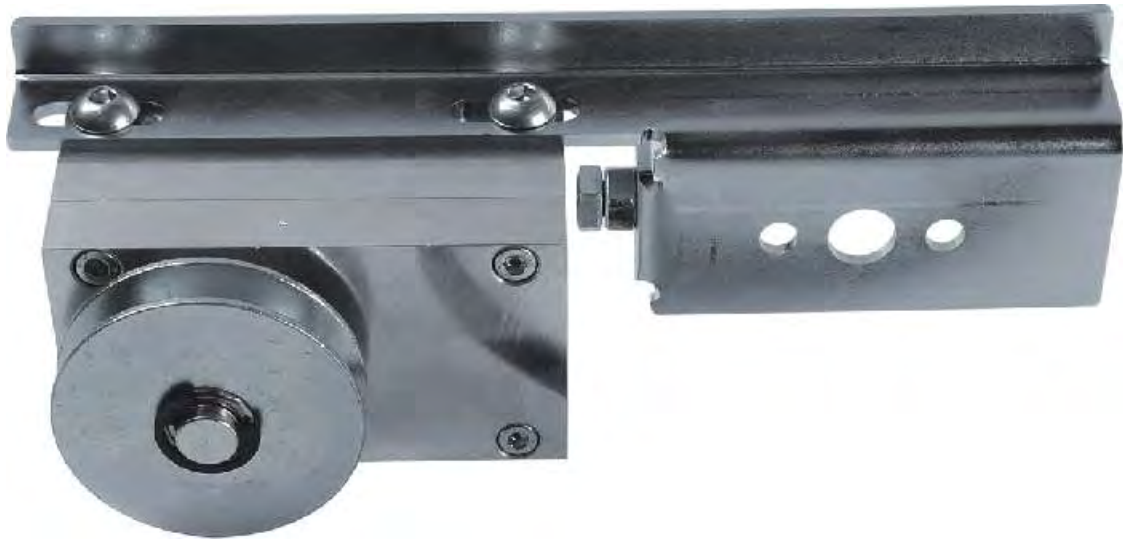

Normally open sliding doors can reach dangerous closing speeds when released, depending on their mass and driving weight. Continuous closure regulators guarantee adjustable and constant-speed slow closure. They consist of a treated steel support that carries the brake and guide pinions mounted on bearings. The sealed aluminium case contains mechanical-hydraulic components including an externally-adjustable regulation valve. The mechanism is fully idle when rotation is in the direction opposite to closure. The devices are mandatory on normally open sliding doors with surface areas in excess of 9 square meters or widths greater than 3 linear meters.



Accessories



RFC/C Fire Alarm Panel

Box in beige ABS

Dimensions (mm) 240 x 150 x 48

Operating voltage 1 Primary, 230 Vac 50-60Hz mains
2 Auxiliary provided by
2 12Vdc 1.1/1.3 Ah batteries
Operational zones : single

RFC Dual Heat & Smoke Detector

Container in White ABS

Dimensions (mm) 110 diameter x 54 height

Operating Voltage 24 Vdc (10,5 – 33 Vdc)

Absorption in Standby 67 mA @ 24Vdc/

Absorption in Alarm 45 mA

Operating Temperature - 20 to + 70 °C

Operational technology: optical, heat (in case of temperature rise, it growing their sensibility to detect the smoke)

Compliance: EN54-7 (smoke)

Use: this dual optical and heat rate of rise detector triggers an alarm condition in case of smoke detection or heat and smoke detection





Finishing

Wide range of choice in order to personalize products with embossed style.

Our products are painted with epoxy powder color with embossed style.

Varnishing deteriorates when exposed to sunbeams.

Optional
Colours



RAL 1013 - Pearl White



RAL 1015 - Light Ivory

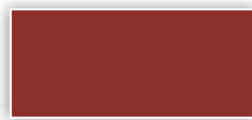

RAL 3000 - Red



RAL 5010 - Gentian Blue



RAL 6034 - Pastel Turquoise

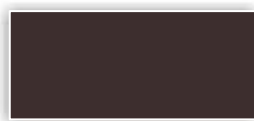

RAL 8017 - Brown



RAL 9002 - Grey White

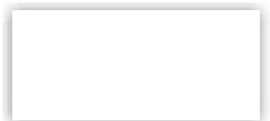

RAL 9010 - White

Standard
Colour



RAL 7035 - Light Grey

N.B. Colours are only for representative use.



STAR EXPORT HOUSE
(Government of India Recognised)



ISO 9001 : 2015, ISO 14001 : 2015
ISO 45001 : 2018

Gandhi Automations operates a policy of continuous development and reserves the right to make technical modifications / replacements without prior notice.

GANDHI
Automations Pvt Ltd

India's No.1 Entrance Automation & Loading Bay Equipment Company

CORPORATE OFFICE

Chawda Commercial Centre, Link Road, Malad (W), Mumbai-400064, India

Tel : +91 22 6672 0200 / 6672 0300 (200 Lines)

Fax : +91 22 6672 0201

Email : sales@geapl.co.in

Website: www.geapl.co.in



TOLL FREE

1800 209 0200

From Anywhere in India

Ahmedabad - 93273 01555
Bengaluru - 93435 09090
Bhopal - 93292 94939
Bhubaneswar - 93385 69889
Chandigarh - 93176 41324
Chennai - 93809 31777
Coimbatore - 93452 99944
Goa - 93731 37970
Guwahati - 93248 98159

Hyderabad - 93473 75737
Indore - 93034 64410
Jaipur - 93520 41024
Jamshedpur - 93219 76556
Kochi - 93882 04774
Kolkata - 93300 60855
Lucknow - 93055 67760
Mangalore - 93797 41352
Nagpur - 93250 45410

New Delhi - 93131 99044
Patna - 93219 76557
Pune - 93245 30710
Raipur - 93524 40068
Ranchi - 93044 95570
Surat - 93270 97410
Vadodara - 93756 41357
Visakhapatnam - 93463 34102